

Age Range: 2-6 Years
 Weight Limit: 65 LBS.
 Surfaces: Hard Surfaces & Grass
 Speed: 3.5 mph For/Rev
 Colors: Gray Body
 w/Black Wheels & Seat
 Intro: 2004
 Suggested Retail: 159.99
 Box Dimensions:
 21.75 x 18.12 x 47.00
 41 lbs.
 Warranty



C3493

Ford F-150 S6V Preschool Series

One Year Vehicle
 6 Months Battery

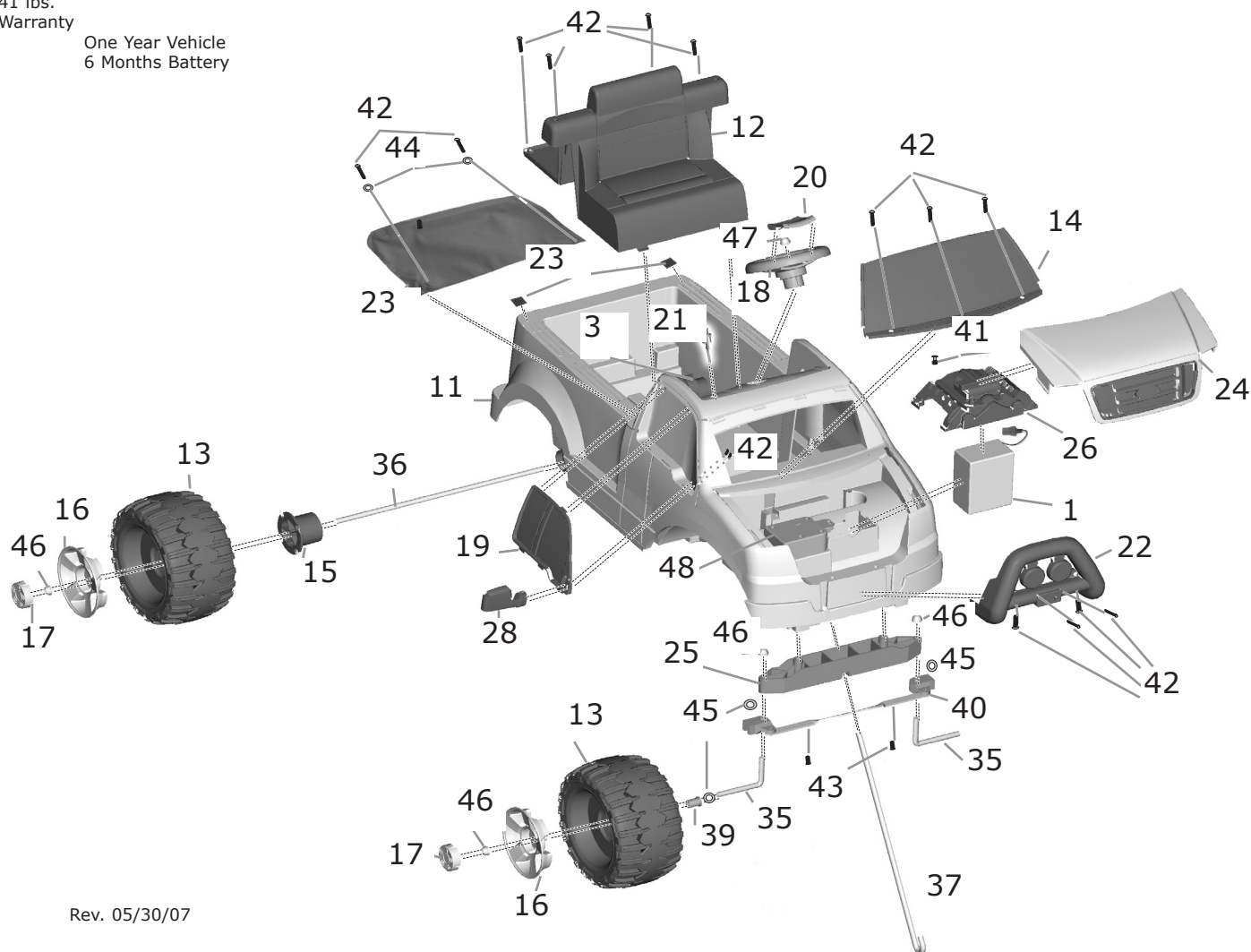

Rev. 05/30/07

Item No.	Description	Part No.	Qty. Item	Part	No. Description Qty.	No.
Electrical Parts-<u>SHOWN</u>						
1.	S6V Battery w/Internal Fuse	00801-0712	1			
3.	Motor Gearbox Assembly	74180-95192				
Hardware / Metal Parts						
11.	Body	N/A	1			
12.	Seat	C3493-2329	1			
13.	Wheel	C3493-2459	4			
14.	Windshield Assembly	3800-7331	1			
15.	Wheel Driver	74460-2249	2			
16.	Hubcap	C3493-2079	4			
17.	Hubcap Cover	C3493-2089	4			
18.	Steering Wheel	C3493-2379	1			
19.	Right & Left Window (Bagged)	3800-74711	1			
20.	Steering Wheel Cover	C3493-2729	1			
21.	Key Housing	C3493-9049	1			
22.	*Brushguard	C3493-9469	1			
23.	*Tonneau w/Fasteners	C3493-5509	1			
24.	Hood/Grill	3800-7346	1			
25.	Steering Linkage Cover	C3493-2279	1			
26.	Pretend Motor	C3493-2159	1			
28.	Mirror Lens R/L (Bagged)	C3493-9079	1			
35.	Front Axle	C3493-4529	2			
36.	Rear Axle	C3493-4519	1			
37.	Steering Column	C3493-4329	1			
39.	Bushing	73610-2689	2			
40.	Steering Linkage	C3493-9319	1			
41.	1" Bolt N/A	0801-0273	2			
42.	8 x 3/4 Screw	0912-8001	17			
43.	12-32 x 1 1/4 Screw N/A					
44.	3/16 Washer N/A	0801-0195	2			
45.	7/16 Washer	0801-0196	4			
46.	.437 Cap Nut	0801-0226	7			
47.	.354 Cap Nut	0801-0604	2			
48.	Battery Retainer Assembly	75548-9409	1			
Parts Not Shown						
	Large Parts Bag	C3493-9459	1			
	Hardware Bag	C3493-9439	1			
	Owners Manual	C3493-0920	1			
	Main Decal Sheet	C3493-0310	1			
	Small Decal Sheet	C3493-0320	1			
	Cap Nut Tool	78640-2629	1			
	PW Emblem	74460-9069	1			
Electrical Parts-<u>NOT SHOWN</u>						
	Gearbox W/out Motor	74550-9279	2			
	Motor Pinion Assembly	74580-9539	2			
	Footswitch (Plunger Type)	00801-0933	1			
	Main Harness Assembly	C3493-9799D	1			
	Control Switch F/R	00801-0885	1			
	Footboard Assembly	C3493-2289	1			
	S6V Charger	00801-0974	1			

N/A = Not

* **Service Bulletin 187**

Bold and Underlined parts are to be purchased and installed by Service Centers only. These items may not be sold directly to consumers by Service Centers or Fisher-Price. *Brushguard and Tonneau cover were eliminated after 12/1/05.